



HAL
open science

Epidemiological Evidence for the Role of the Hemoglobin Receptor, HmbR, in Meningococcal Virulence

Odile Harrison, Nicholas Evans, Jessica Blair, Holly Grimes, Colin Tinsley, Xavier Nassif, Paula Kriz, Roisin Ure, Steve Gray, Jeremy Derrick, et al.

► **To cite this version:**

Odile Harrison, Nicholas Evans, Jessica Blair, Holly Grimes, Colin Tinsley, et al.. Epidemiological Evidence for the Role of the Hemoglobin Receptor, HmbR, in Meningococcal Virulence. *Journal of Infectious Diseases*, Oxford University Press (OUP), 2009, 200 (1), pp.94-98. 10.1086/599377 . hal-03665200

HAL Id: hal-03665200

<https://hal-agroparistech.archives-ouvertes.fr/hal-03665200>

Submitted on 11 May 2022

HAL is a multi-disciplinary open access archive for the deposit and dissemination of scientific research documents, whether they are published or not. The documents may come from teaching and research institutions in France or abroad, or from public or private research centers.

L'archive ouverte pluridisciplinaire **HAL**, est destinée au dépôt et à la diffusion de documents scientifiques de niveau recherche, publiés ou non, émanant des établissements d'enseignement et de recherche français ou étrangers, des laboratoires publics ou privés.

Published in final edited form as:

J Infect Dis. 2009 July 1; 200(1): 94–98. doi:10.1086/599377.

Epidemiological evidence for the role of the haemoglobin receptor, HmbR, in meningococcal virulence

Odile B. Harrison^{1,*,#}, Nicholas J. Evans^{2,7,*}, Jessica M. Blair¹, Holly S. Grimes¹, Colin R. Tinsley³, Xavier Nassif⁴, Paula Kriz⁵, Roisin Ure¹, Steve J. Gray⁶, Jeremy P. Derrick⁷, Martin C.J. Maiden¹, and Ian M. Feavers²

¹The Department of Zoology, University of Oxford, South Parks Road, Oxford OX1 3SY, UK

²National Institute for Biological Standards and Control, Blanche Lane, South Mimms, Hertfordshire EN6 3QG, UK

³Laboratoire de Microbiologie et Génétique Moléculaire, AgroParisTech, site de Grignon, 78550 Thiverval-Grignon, France

⁴Institut National de la Santé et de la Recherche Médicale U570, Faculté de Médecine Necker, 75015 Paris, France

⁵National Reference Laboratory for Meningococcal Infections, National Institute of Public Health, Prague, Czech Republic

⁶Meningococcal Reference Unit, RSID, Health Protection Agency, Manchester Royal Infirmary, Oxford Road, Manchester. M13 9WZ, UK

⁷Faculty of Life Sciences, University of Manchester, 131 Princess Street, Manchester, M1 7DN, UK

Abstract

The distribution of the haemoglobin receptor gene (*hmbR*) was investigated in disease and carried *Neisseria meningitidis* isolates revealing that the gene occurred at a significantly higher frequency in disease isolates compared to those obtained from carriage. Where *hmbR* was absent, the locus was occupied by the cassettes *exl2* or *exl3*, or with a “pseudo *hmbR*” gene designated *exl4*. The *hmbR* locus in published *N. meningitidis* genomes, as well as *N. gonorrhoeae* and *N. lactamica* ST-640, exhibited characteristics of a pathogenicity island. These data are consistent with a role for the *hmbR* gene in meningococcal disease.

Keywords

haemoglobin receptor; meningococcal disease; virulence; pathogenicity island

#Correspondence to: Dr Ian M. Feavers (ifeavers@nibsc.ac.uk). National Institute for Biological Standards and Control, Division of Bacteriology, Blanche Lane, South Mimms UK Tel: +44 1707 641445 Fax: +44 1707 641054 and Dr Odile B. Harrison (odile.harrison@zoo.ox.ac.uk). Department of Zoology, University of Oxford, South parks Rd, Oxford, UK Tel: +44 1865 281538 Fax: +44 1865 281275.

*These authors contributed equally to this paper.

Current affiliations: NJE: Department of Veterinary pathology, Vet Science Building, Faculty of Veterinary Science, University of Liverpool, Liverpool L69 3BX. JMB: Division of Immunity and Infection, The Medical School, The University of Birmingham, Edgbaston B15 2TT, UK. RU: Scottish Meningococcus and Pneumococcus Reference Laboratory (SMPRL), Stobhill Hospital, Glasgow, G21 3UW.

The authors of this paper do not have any commercial or other associations that might pose a conflict of interest (e.g. pharmaceutical stock ownership, consultancy, advisory board membership, relevant patents, or research funding).

This information was presented at the 16th International Pathogenic Neisseria Conference, Rotterdam, The Netherlands. September 7-12 2008, 1st Session Epidemiology.

INTRODUCTION

The documented absence of the haemoglobin receptor gene among a number of *Neisseria meningitidis* isolates led to the discovery that the gene was located on a genetic island containing multiple cassettes including the putative proteins Ex12, Ex13 followed by other unidentified open reading frames (ORF) [1, 2]. Lack of the *hmbR* gene among some meningococcal isolates, combined with the association of the gene with mobile genetic elements, indicates that it may form part of a DNA virulence island recently acquired by meningococci [3, 4].

Here the distribution of the *hmbR* gene among over 700 disease and carriage-associated meningococci from three separate isolate collections was investigated, revealing a statistically significant association between disease and the presence of the *hmbR* gene. *In silico* analysis of the *hmbR* genetic locus among the genomes belonging to *N. meningitidis* isolates Z2491, FAM18, MC58, NMC053442, *N. gonorrhoeae* FA1090 and *N. lactamica* ST-640 indicated that the gene was located on a putative pathogenicity island. DNA arrays comparing the genomes of isolates belonging to the ST-41/44 clonal complex showed a higher likelihood of the *hmbR* gene being found among isolates from cases of invasive disease.

METHODS

Meningococcal isolates

Three isolate collections were examined. The first comprised 96 mainly disease-associated isolates assembled globally from 1937 to 1996 and described by Maiden *et al* [5]. The second contained 203 carried and invasive isolates forming part of a collection assembled in 1993 in the Czech Republic [6]. The third collection included 462 isolates obtained in England and Wales between 1999 and 2000, of which 265 were carried and 197 were disease-associated. These isolates were from the Meningococcal Reference Unit and the UK carriage study.

PCR amplification and nucleotide sequence determination

The complete *hmbR* gene was amplified using primers PN1 5'-CCGGAAGGAATGATGCCGCACAGG-3' and NE3 5'-TTAAACTTCCATTCCAGCG-3'. Isolates *hmbR* negative were further screened by PCR using primers *hemO* 5'-GAATGATGCCGCAGAG-3' and *col2* 5'-GCATTCAGGTCAAAATCC-3', which are located in the *hemO* and *col* genes on either side of the genetic island thus amplifying the whole region. Following this procedure, amplicons were sequenced using the primers *hemO*, *ex12-R* 5'-CCGTCAGGGATTTACCGGC-3', *ex13-F* 5'-GCCTGCAAATACGCCGAAGCC-3', *ex13-R* 5'-GCCTGCAAATACGCCGAAGCCG-3', *ex13-seqF* 5'-GGCGGAGTGCAAAATGATGC-3' and *ex13-seqR* 5'-GCCATCTTTAATTTAGCCGC-3' revealing the exchangeable cassette replacing the *hmbR* gene. Nucleotide accession numbers can be found in the Appendix A1.

Whole genome comparisons of the ST41/44 clonal complex meningococci by DNA array

Techniques and data analysis were as described previously [7, 8] with data deposited in the Array express database www.ebi.ac.uk/arrayexpress/query/entry with accession number E-MEXP-343.

Statistical analyses

These were conducted using Intercooled STATA version 10 software for windows. Multivariable logistic regression models were used to estimate the strength of association between *hmbR* status and whether the isolate originated from a healthy carrier or a clinical case.

RESULTS

Distribution of the *hmbR* gene and association with disease

A total of 761 *N. meningitidis* isolates were screened for the presence of the *hmbR* gene. A minority of disease isolates lacking the gene were present with 11 (14%), 1 (7%) and 5 (3%) *hmbR* negative isolates present in all three collections respectively, indicative of a significant association of the gene with virulence (Table 1). The odds ratio for the association of the *hmbR* gene with all disease isolates and for each isolate collection provided further evidence for the predisposition of disease isolates to contain the *hmbR* gene. The over-representation of the gene among disease *N. meningitidis* isolates was apparent with the hyper-invasive lineages ST-4, ST-5, ST-8, ST-11, ST-18 and ST-32 exclusively *hmbR* positive (Appendix A2).

Association of *exl2* and *exl3* with carried clonal complexes

Isolates lacking the *hmbR* gene were found among clonal complexes ST-1, ST-22, ST-23, ST-41/44, ST-60, ST-106, ST-198, ST-549 in addition to many isolates currently unassigned to a clonal complex (Appendix A2). The *exl2* exchangeable cassette was principally associated with serogroup Y isolates of the ST-23 clonal complex (59%). The *exl3* genetic island was present in clonal complexes ST-1, ST-106, ST-549, ST-22 and ST-60.

Characterisation of a “pseudo *hmbR*” gene designated *exl4*

A total of 28 isolates from the clonal complexes ST-41/44 and ST-198 lacked both *exl* genetic islands and the *hmbR* gene (Appendix A2). BLAST searches of the sequence replacing *exl2*, *exl3* and *hmbR* in these isolates revealed 97% sequence identity with a “pseudo *hmbR* gene” identified in the sequenced genome of isolate NMC053442, a Chinese ST-4821 serogroup C isolate [9]. Further analysis of the 2, 477 bp long “pseudo *hmbR* gene” belonging to isolate NMC053442 revealed 62% sequence identity over a length of 977 bp fragments with published *hmbR* sequences indicating that this may not be an *hmbR* gene but may instead contain fragments of the *hmbR* gene. Furthermore, the “pseudo *hmbR* gene” identified in the ST-41/44 and ST-198 isolates, as well as isolate NMC053442, was found to contain a polydeoxyguanosine phosphate tract occurring at 663 bp, much earlier than that of published *hmbR* genes, which are known to occur at 1159 bp. Consequently, this novel ORF replacing *hmbR* was designated *exl4*.

Clonal Complex ST-41/44 and *hmbR*

DNA arrays were used to compare the genomes of isolates belonging to recognised invasive sequence types (e.g. ST-41) with isolates belonging to sequence types not associated with disease (e.g. ST-44, ST-110 and ST-111). Within the ST-41/44 clonal complex, the association of *hmbR* with disease *N. meningitidis* isolates was significant ($P < 0.0001$) with 65 (98%) of the 66 disease-associated isolates containing the *hmbR* gene compared to 41 (69%) out of 59 carriage isolates. Genome comparisons between ST-41 and ST-44 isolates did not show any other major differences.

Genetic arrangement of the *hmbR* and *exI* loci in *Neisseria*

In silico analysis of the *hmbR* locus among the sequenced genomes from *N. meningitidis*, *N. gonorrhoeae* and *N. lactamica* identified seven different cassettes (A-G). Region I contained *hemO*, a gene involved in the catabolism of heme. Region II included the collagenase gene homologue, *col*, bordered by a 27 bp inverted repeat. Region III contained the *hmbR* gene, or the exchangeable islands *exI2*, *exI3* and *exI4* (Figure 1). The previously documented *hmbR* locus belonging to *N. meningitidis* GA0929 containing the *exI2* exchangeable cassette was also included in the alignment [2]. Multiple unidentified ORFs, Correia elements [10] and inverted repeats were identified - all key characteristics of pathogenicity islands.

DISCUSSION

Neisseria meningitidis remains a major cause of meningitis and septicaemia worldwide, however despite its pathogenic potential, *N. meningitidis* is also a common human commensal [11, 12]. The capsular polysaccharide, type IV pili and iron acquisition systems are all necessary pathogenesis determinants, but while each of these factors is required for invasive disease it is not sufficient, with the likelihood that many other genetic factors contribute to the ability of a meningococcus to cause invasive disease. The search for new virulence factors in this species is hampered by the lack of a suitable animal model representative of human disease. An alternative strategy is to employ a molecular epidemiological approach to establish a statistical association of a gene with disease. Here, the distribution of the haemoglobin receptor gene was examined in over 700 meningococci isolated from cases of disease and asymptomatic carriage.

The *hmbR* gene was first identified in 1995 and the importance of haemoglobin utilisation during invasion was demonstrated when an *N. meningitidis* *hmbR* mutant was attenuated in an infant rat model of meningococcal infection [13]. Data presented in this study described a statistically significant association of the *hmbR* gene with disease *N. meningitidis* isolates, providing epidemiological evidence for the importance of the *hmbR* gene in meningococcal virulence (Table 1). Combined with the documented low diversity of the gene [14], these data indicate a potential role of HmbR in future vaccines.

The absence of *hmbR* among *N. meningitidis* isolates has been reported [1] and, due to the prevalence of the *hpuAB* complex among those isolates, it was suggested that *hmbR* may have been a recent acquisition by meningococci. Examination of the genetic island among the genomes from *N. meningitidis* FAM18, Z2491, MC58 and NMC053442, *N. gonorrhoeae* FA1090 and *N. lactamica* ST-640 revealed that the region contained many inverted repeats, a feature of pathogenicity islands (PAIs) (Figure 1) [4]. Further PAI characteristics included an overall G+C content of 47% below the mean 51% of the *Neisseria* genome content, the presence of cryptic ORFs, the insertion sequence IS1060 in *N. gonorrhoeae* FA1090 as well as Correia elements among *N. meningitidis* isolates [3]. Finally, the *hmbR* locus was not composed of a homogeneous piece of DNA but was instead made up of several mosaic-like ORFs, another key PAI feature [3, 4, 15].

In the present study, a minority of 17 (5%) of the 314 disease *N. meningitidis* isolates from all three isolate collections lacked the *hmbR* gene indicative of the over-representation of the gene among disease isolates (Table 1). Most cases of meningococcal disease are caused by only a few clonal complexes of related sequence types (STs) referred to as hyper-invasive lineages [11]. The association of the *hmbR* gene with disease was apparent in isolates belonging to such lineages including ST-4, ST-5, ST-8, ST-11, ST-18 and ST-32 where, without exception, all isolates contained the gene (Appendix A2).

The importance of the *hmbR* gene in disease isolates was consistent among meningococci of the ST-41/44 clonal complex, members of which have been the prevalent cause of disease in parts of Northern Europe during the past decade and responsible for epidemic disease in New Zealand [16]. This complex of closely related clones is unusual in that it is centred on two sequence types, ST-41 and ST-44, rather than possessing a single central ST [5]. ST-41 related meningococci are in general isolated from cases of invasive disease, whereas ST-44 related clones are typically associated with carriage [11]. In the current study, all of the ST-41 related isolates possessed an *hmbR* gene. Conversely, all of those isolates lacking the gene were among ST-44 related meningococci. Using this DNA array, no other major differences were observed between the ST-41 and ST-44 related meningococci.

Alternative cassettes for the HmbR locus were the putative lipoproteins Ex12 and Ex13 [2]. The function of both Ex12 and Ex13 is unknown, however they both present 69% sequence identity with the TbpB-like protein, GNA2132, as well as TbpB, LbpB and HpuA - consistent with a putative role in iron uptake or metabolism [2]. In agreement with Kahler *et al*, the genetic island, *ex12*, was predominantly found among meningococci with a serogroup Y polysaccharide capsule belonging to the ET-508/ST-23 clonal complex (Appendix A2). The predominance of *ex12* in meningococci from the ST-23 clonal complex may be a result of clonal expansion. Clonal complexes are often associated with particular phenotypic characteristics such as serogroup or subcapsular antigens [17].

The *ex13* genetic island was predominantly found among meningococci belonging to the lineages ST-22, ST-106, ST-549 and ST-60 (Appendix A2). However, in agreement with previous analysis, *ex13* was also found among isolates in the ST-1 clonal complex which, in contrast, primarily contained disease-causing serogroup A meningococci [2]. The absence of the *hmbR* gene among serogroup A meningococci has been documented, however all of the isolates contained the *hpuB* gene part of the HpuAB bipartite receptor for Hb and haemoglobin acquisition indicating that this was the main haemoglobin receptor for serogroup A meningococci [1]. In the present study, all of the serogroup A lineage ST-5 (N=13) and ST-7 (N=2) meningococci contained *hmbR* genes, suggesting that replacement of the *hmbR* gene with the *ex13* locus was limited to serogroup A clonal complex ST-1 meningococci.

A total of 19 clonal complex ST-41/44 and nine ST-198 isolates contained neither the *hmbR* gene nor either of the *ex1* genetic islands. Instead the locus was replaced with an ORF designated *ex14* sharing 97 % identity with the “pseudo *hmbR*” gene from the recently sequenced genome of ST-4821 isolate NMC053442 [9]. The “pseudo *hmbR*” gene belonging to isolate NMC053442 was highly divergent from other *hmbR* genes with BLAST searches revealing 62% identity in a 977 bp fragment of the *hmbR* gene. Previous studies have documented the relatively high conservation of *hmbR* among *N. meningitidis* isolates raising the question of whether the gene identified in the Chinese isolate NMC053442 may be another *ex1* island containing a *hmbR* fragment [14].

In conclusion, an epidemiological survey of the *hmbR* gene among both disease and carriage associated *N. meningitidis* isolates revealed a statistically significant association of the *hmbR* gene with virulent *N. meningitidis* isolates consistent with a role for *hmbR* during pathogenesis. This study highlights the power of molecular epidemiological studies in determining novel virulence determinants.

Supplementary Material

Refer to Web version on PubMed Central for supplementary material.

Acknowledgments

This work was funded by the National Institute for Biological Standards and Control (NIBSC), the Wellcome Trust and the University of Manchester.

REFERENCES

- Richardson AR, Stojiljkovic I. HmbR, a hemoglobin-binding outer membrane protein of *Neisseria meningitidis*, undergoes phase variation. *J Bacteriol.* 1999; 181:2067–74. [PubMed: 10094683]
- Kahler CM, Blum E, Miller YK, Ryan D, Popovic T, Stephens DS. *exI*, an exchangeable genetic island in *Neisseria meningitidis*. *Infect Immun.* 2001; 69:1687–96. [PubMed: 11179344]
- Hacker J, Kaper JB. Pathogenicity islands and the evolution of microbes. *Annu Rev Microbiol.* 2000; 54:641–79. [PubMed: 11018140]
- Gal-Mor O, Finlay BB. Pathogenicity islands: a molecular toolbox for bacterial virulence. *Cell Microbiol.* 2006; 8:1707–19. [PubMed: 16939533]
- Maiden MC, Bygraves JA, Feil E, et al. Multilocus sequence typing: a portable approach to the identification of clones within populations of pathogenic microorganisms. *Proc Natl Acad Sci U S A.* 1998; 95:3140–5. [PubMed: 9501229]
- Jolley KA, Kalmusova J, Feil EJ, et al. Carried meningococci in the Czech Republic: a diverse recombining population. *J Clin Microbiol.* 2000; 38:4492–8. [PubMed: 11101585]
- Bille E, Zahar JR, Perrin A, et al. A chromosomally integrated bacteriophage in invasive meningococci. *J Exp Med.* 2005; 201:1905–13. [PubMed: 15967821]
- Perrin A, Bonacorsi S, Carbonnelle E, et al. Comparative genomics identifies the genetic islands that distinguish *Neisseria meningitidis*, the agent of cerebrospinal meningitis, from other *Neisseria* species. *Infect Immun.* 2002; 70:7063–72. [PubMed: 12438387]
- Peng J, Yang L, Yang F, et al. Characterization of ST-4821 complex, a unique *Neisseria meningitidis* clone. *Genomics.* 2008; 91:78–87. [PubMed: 18031983]
- Correia FF, Inouye S, Inouye M. A 26-base-pair repetitive sequence specific for *Neisseria gonorrhoeae* and *Neisseria meningitidis* genomic DNA. *J Bacteriol.* 1986; 167:1009–15. [PubMed: 3091577]
- Yazdankhah SP, Kriz P, Tzanakaki G, et al. Distribution of serogroups and genotypes among disease-associated and carried isolates of *Neisseria meningitidis* from the Czech Republic, Greece, and Norway. *J Clin Microbiol.* 2004; 42:5146–53. [PubMed: 15528708]
- Cartwright KA, Stuart JM, Jones DM, Noah ND. The Stonehouse survey: nasopharyngeal carriage of meningococci and *Neisseria lactamica*. *Epidemiol Infect.* 1987; 99:591–601. [PubMed: 3123263]
- Stojiljkovic I, Hwa V, de Saint Martin L, et al. The *Neisseria meningitidis* haemoglobin receptor: its role in iron utilization and virulence. *Mol Microbiol.* 1995; 15:531–41. [PubMed: 7783623]
- Stojiljkovic I, Larson J, Hwa V, Anic S, So M. HmbR outer membrane receptors of pathogenic *Neisseria* spp.: iron-regulated, hemoglobin-binding proteins with a high level of primary structure conservation. *J Bacteriol.* 1996; 178:4670–8. [PubMed: 8755899]
- Hacker J, Carniel E. Ecological fitness, genomic islands and bacterial pathogenicity. A Darwinian view of the evolution of microbes. *EMBO Rep.* 2001; 2:376–81. [PubMed: 11375927]
- Dyet K, Devoy A, McDowell R, Martin D. New Zealand's epidemic of meningococcal disease described using molecular analysis: implications for vaccine delivery. *Vaccine.* 2005; 23:2228–30. [PubMed: 15755601]
- Urwin R, Russell JE, Thompson EA, Holmes EC, Feavers IM, Maiden MC. Distribution of surface protein variants among hyperinvasive meningococci: implications for vaccine design. *Infect Immun.* 2004; 72:5955–62. [PubMed: 15385499]

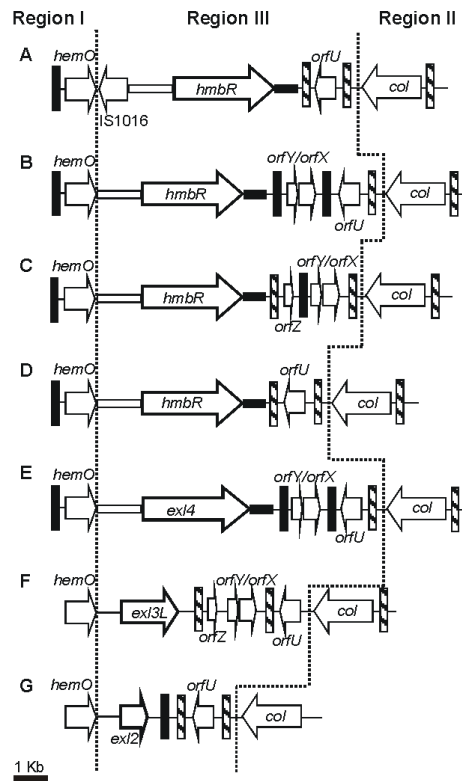

Figure 1. Genetic arrangement of the *hmbR* locus among *Neisseria*

A. *N. gonorrhoeae* FA1090 [accession number AE004969]; B. *N. meningitidis* FAM18 [accession number AM421808]; C. *N. meningitidis* MC58 [accession number AE002098]; D. *N. meningitidis* Z2491 [accession number AL157959]; E. *N. meningitidis* NMC053442 [accession number CP000381]; F. *N. lactamica* ST-640 and G. *N. meningitidis* isolate GA0929 [accession number AF319532]. Annotation was derived from the published genome data available at TIGR, the Sanger institute and data published by Kahler *et al* [2]. Permission for use of the *N. lactamica* genome data was kindly given by Julian Parkhill at the Sanger Institute and genome data is available at http://www.sanger.ac.uk/Projects/N_lactamica/.

Each ORF is represented by an arrow the direction of which indicating the theoretical direction of transcription. Thin black vertical bars indicate Correia elements, hatched vertical bars represent inverted repeats. Open horizontal blocks denote highly conserved 174 bp regions located at the 5' end of the *hmbR* and *exI4* ORFs. Black horizontal blocks represent 112 bp conserved regions located immediately after the *hmbR* or *exI4* ORFs. Both conserved regions were not found in *N. lactamica* or *N. meningitidis* GA0929.

Table 1Distribution of the *hmbR* gene in all collections

Isolate collections	<i>hmbR</i> positive (%)	<i>hmbR</i> negative (%)	Disease association OR [95% confidence interval]	Total
107 MLST Disease isolates	68 (86)	11 (14)	3.63 [0.98 to 13.35]	79
107 MLST Carriage isolates	10 (59)	7 (41)		17
Czech 1993 Disease isolates	37 (97)	1 (3)	3.51 [1.19 to 10.40]	38
Czech 1993 Carriage isolates	125 (76)	40 (24)		165
UK 1999 Disease isolates	192 (97)	5 (3)	10.30 [4.033 to 26.26]	197
UK 1999 Carriage isolates	210 (79)	55 (21)		265
All Disease isolates	297 (95)	17 (5)	4.42 [2.72 to 7.16]	314
All Carriage isolates	345 (77)	102 (23)		447
Total	642	119		761

Results are significant ($P < 0.0001$). Relative risk = 1.26 [95% confidence interval: 1.18 to 1.34].